

Ponorné kladivo **PMK600 HQ**

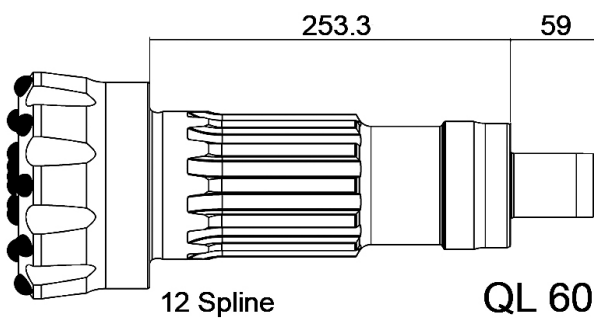

SPECIFIKACE KLADIVA		SPOTŘEBA VZDUCHU			
		PSI	BAR	CFM	m ³ /min
VÁHA	106 kg	150	10,3	329	9,31
DÉLKA	1180 mm	200	13,8	509	14,4
VNĚJŠÍ PRUMĚR	145 mm	250	17,2	707	20
MAX. PRAC.TLAK	24 BAR	300	20,7	930	26,3
ZÁVIT API REG	3" 1/2	350	24	1034	38

DŘÍK DLÁTA - INGERSOLL RAND QL 60 - ATLAS COPCO COP 64 GOLD



Dláto 165- 216 mm, 12 drážek

Poz.	popis	ND číslo
1	hor. unašeč	OC-01-06
2	ventil	OC-02-06
3	pružina ve.	OC-03-06
4	rozvaděč	OC-04-06
5	pružina	OC-05-06
6	vodítko	OC-06-06
7	přidrž. kroužek	OC-07-06
8	píst	OC-08-06
9	kroužek	OC-09-06
10	vod.pouzdro	OC-10-06
11	aret. krouž.	OC-11-06
12	dol. unašeč	OC-12-06
13	O-kroužek	OC-13-06
14	O-kroužek	OC-14-06
15	O-kroužek	OC-15-06
16	válec	OC-16-06

